

15.0	J
13.0	I
9.5	H
9.0	G
8.5	F
7.5	E
6.5	D
6.0	C
5.0	B
4.3	A
高度H (mm)	X=

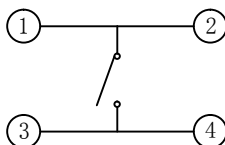

电路图

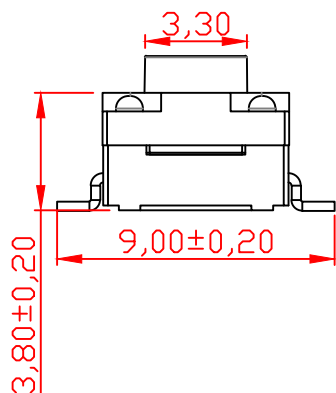
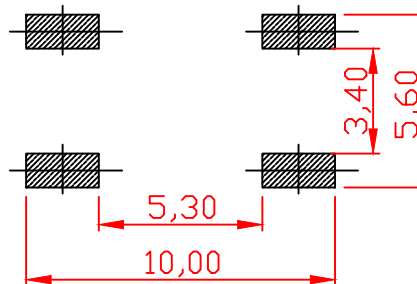

PCB. 焊接图

主要技术规格:

1. 额定值: 50mA DC12V
2. 接触电阻: 100mΩ
3. 操作力: 180/250gf±50gf
4. 行程: 0.25±0.1mm
5. 绝缘电阻: 100MΩ
6. 抗电强度: 250V 50HZ 1min.
7. 寿命: 100,000Cycles
8. 防水等级: IP67

材料:

- ①按钮: PPA耐温280 (黑色)
- ②盖板: PPA耐温280 (黑色)
- ③防水垫: 硅胶耐温280 (黑色)
- ④防水膜: PI耐温280 (黑色)
- ⑤弹片: 不锈钢 (覆银)
- ⑥本体: PPA耐温280 (黑色)
- ⑦卡件: 黄铜 (镀银)

HADFU ELECTRONCS TECHNOLOGY CO.,LTD

COPYRIGHT RESERVED,PLEASE DO NOT COPY.

PART NAME		SWITCH		DRAWING		Y,C,ZHANG		DWG.No.		SBICL	
PART NO.		TD-1839SP-X		CHECK		G.C.Chen		REV.		A1	
UNIT : mm	TOLERANCE OTHERWISE	UP TO 5	±0.2	ANGLE	APPROVAL	DATE	14-03-2013	PAGE	1 OF 1		
		ABOVE 5~30	±0.3							0°±5'	
		ABOVE 30	±0.5		SCALE	2:1					
		ANGLE	±3'								