

安装图 (PCB LAYOUT PLAN)

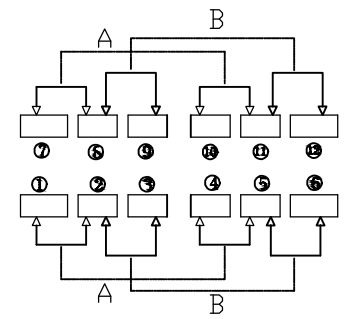
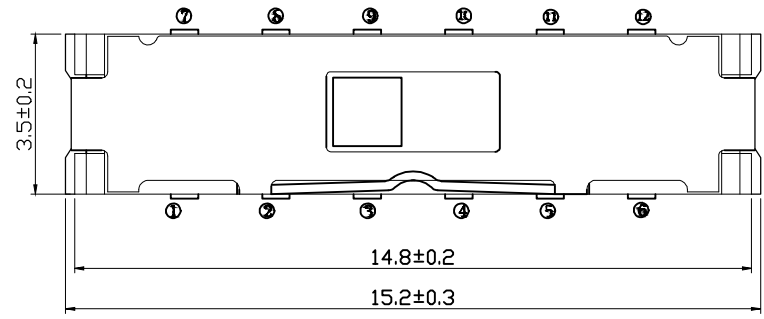

电路图 (CIRCUIT DIAGRAM)

- 主要技术规格:
1. 额定值: 50mA DC12V
 2. 接触电阻: 50mΩ
 3. 操作力: 250gf±100gf
 4. 行程: 2+0.2mm
 5. 绝缘电阻: 100MΩ
 6. 抗电强度: 250V 50HZ 1Min.
 7. 寿命: 1万Cycles

材料:
 A底座: LCP (黑色)
 B端子: 磷铜 (镀银)
 C簧片: 磷铜 (镀银)
 D胶柄: PA46 (黑色)
 E盖板: 不锈钢 (清洗)

HADFU ELECTRONCS TECHNOLOGY CO.,LTD

COPYRIGHT RESERVED,PLEASE DO NOT COPY.

| | | | | | | | |
|-----------|----|------------------------|------------|---------|-----------|---------|------------|
| PART NAME | | SWITCH | | DRAWING | Y,C,ZHANG | DWG.No. | SBICL |
| PART NO. | | MSS-42D01G2 | | CHECK | G.C.Chen | REV. | A1 |
| UNIT : | mm | TOLERANCE OTHERWISE | UP TO 5 | ±0.2 | APPROVAL | DATE | 14-03-2013 |
| | | | ABOVE 5~30 | ±0.3 | | SCALE | PAGE |
| | | | ABOVE 30 | ±0.5 | | | 1 OF 1 |
| | | | ANGLE | ±3° | | | |