

RoHS
Compliant

- CONTACT CURRENT RATING: 1A.
- CONTACT RESISTANCE: 50 mΩ MAX.;
- INSULATION RESISTANCE: 100MΩ MIN.;
- DIELECTRIC WITHSTANDING: 500V AC MIN.;
- DURABILITY: 5,000 CYCLES MIN.;
- CONNECTOR MATING FORCES: 30N MAX.;
- CONNECTOR UNMATING FORCES: 3N MIN.;

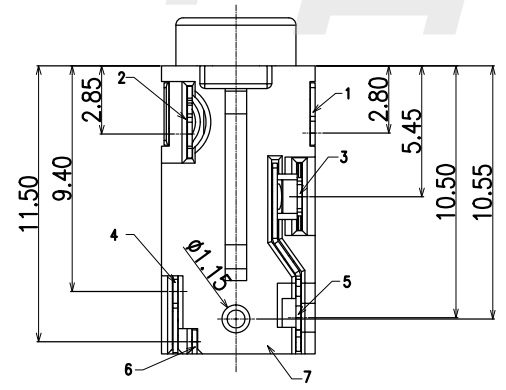
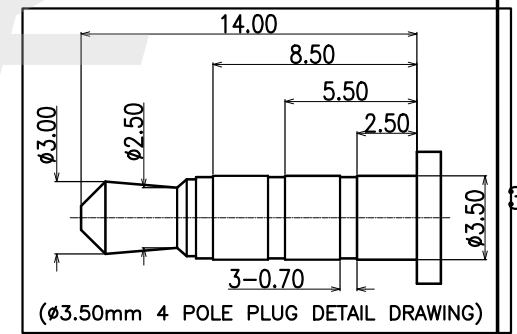
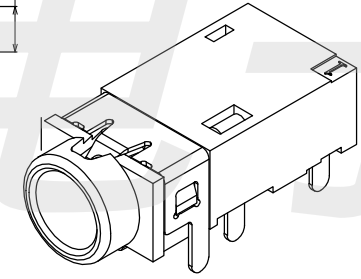
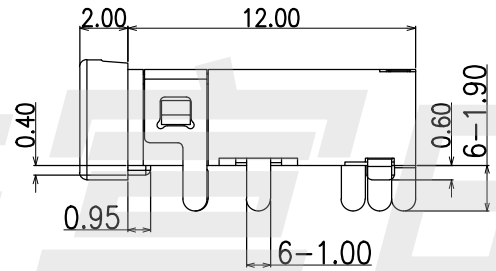
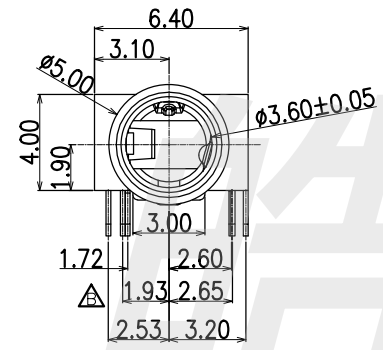
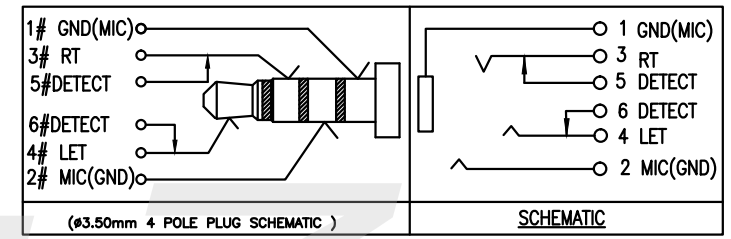
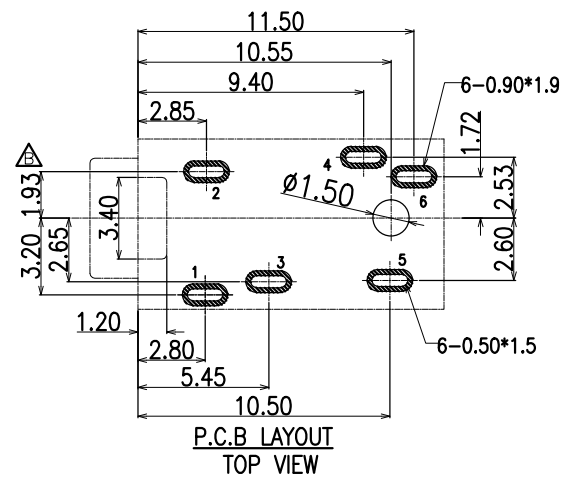
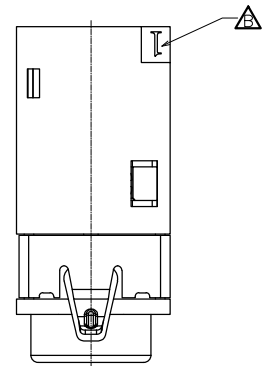

7	HOUSING	1	PPA COLOR BLACK	
6	TERMINAL 6#	1	BRASS; NICKEL(40u"MIN.) UNDER PLATING OVERALL,GOLD FLASH PLATING ON SOLDER AREA	T=0.20mm
5	TERMINAL 5#	1	BRASS; NICKEL(40u"MIN.) UNDER PLATING OVERALL,GOLD FLASH PLATING ON SOLDER AREA	T=0.20mm
4	TERMINAL 4#	1	STAINLESS STEEL; NICKEL(40u"MIN.)UNDER PLATING OVERALL,GOLD FLASH PLATING ON SOLDER AREA ;GOLD FLASH PLATING ON CONTACT AREA	T=0.20mm
3	TERMINAL 3#	1	PHOSPHOR BRONZE; NICKEL(40u"MIN.)UNDER PLATING OVERALL,GOLD FLASH PLATING ON SOLDER AREA ;GOLD FLASH PLATING ON CONTACT AREA	T=0.20mm
2	TERMINAL 2#	1	PHOSPHOR BRONZE; NICKEL(40u"MIN.) UNDER PLATING OVERALL,GOLD FLASH PLATING OVERALL;	T=0.20mm
1	TERMINAL 1#	1	PHOSPHOR BRONZE; NICKEL(40u"MIN.) UNDER PLATING OVERALL,GOLD FLASH PLATING OVERALL;	T=0.20mm
ITEM	NAME	Q'TY	DESCRIPTION	NOTE

HAOFU ELECTRONCS TECHNOLOGY CO.,LTD

COPYRIGHT RESERVED,PLEASE DO NOT COPY.

PART NAME		PHONE JACK		DRAWING	Y,C,ZHANG	DWG.No.	SBICL
PART NO.		PJ-3973		CHECK	G.C.Chen	REV.	A1
UNIT :	TOLERANCE OTHERWISE	UP TO 5	±0.2	APPROVAL	DATE	PAGE	1 OF 1
		ABOVE 5 ~30	±0.3				
mm		ABOVE 30	±0.5	SCALE			
		ANGLE	±3°				

F

E

D

C

B

A