

SPECIFICATION:

1. Material:
HOUSING&MOLDING:HIGH TEMPERATURE RESISTANT PLASTIC,UL94 V-0
CONTACTS:COPPER ALLOY
SHELL:SUS304-1/2H,T=0.30
2. Mechanical:
2.1.Mating force:5~20Nf Max.;
2.2.Unmating force:6~20Nf Min.;
2.3.Durability:10000 Cycles;
- 3.Electrical:
3.1.Current Rating:3A Max.;
3.2.Voltage Rating:20V Max.;
3.3.Dielectric Withstanding volage:100VAc;
3.4.Contact resistance:40m Ohms Max.;
3.5.Insulation Resistance:100M Ohms Min.;
- 4.Environmental:
4.1.Operating temperature:-40°C~+85°C;
4.2.Wetting Temperature:265±5°C,5±0.5s

NO.	DIM A	COLOR	镀金1u"	镀金3u"	镀金1u"+雾锡	镀金3u"+雾锡
1	1.3	WHITE	1014-FGW001	1014-FHW001	1014-FAW001	1014-FBW001
2		BLACK	1014-FGB001	1014-FHB001	1014-FAB001	1014-FBB001
3	1.8	WHITE	1014-FGW002	1014-FHW002	1014-FAW002	1014-FBW002
4		BLACK	1014-FGB002	1014-FHB002	1014-FAB002	1014-FBB002

USB TYPE-C PIN ASSIGNMENTS

PIN NUMBER	SIGNAL NAME	PIN NUMBER	SIGNAL NAME
A1	GND	B12	GND
A4	VBUS	B9	VBUS
A5	CC1	B7	Dn2
A6	Dp1	B6	Dp2
A7	Dn1	B5	CC2
A9	VBUS	B4	VBUS
A12	GND	B1	GND

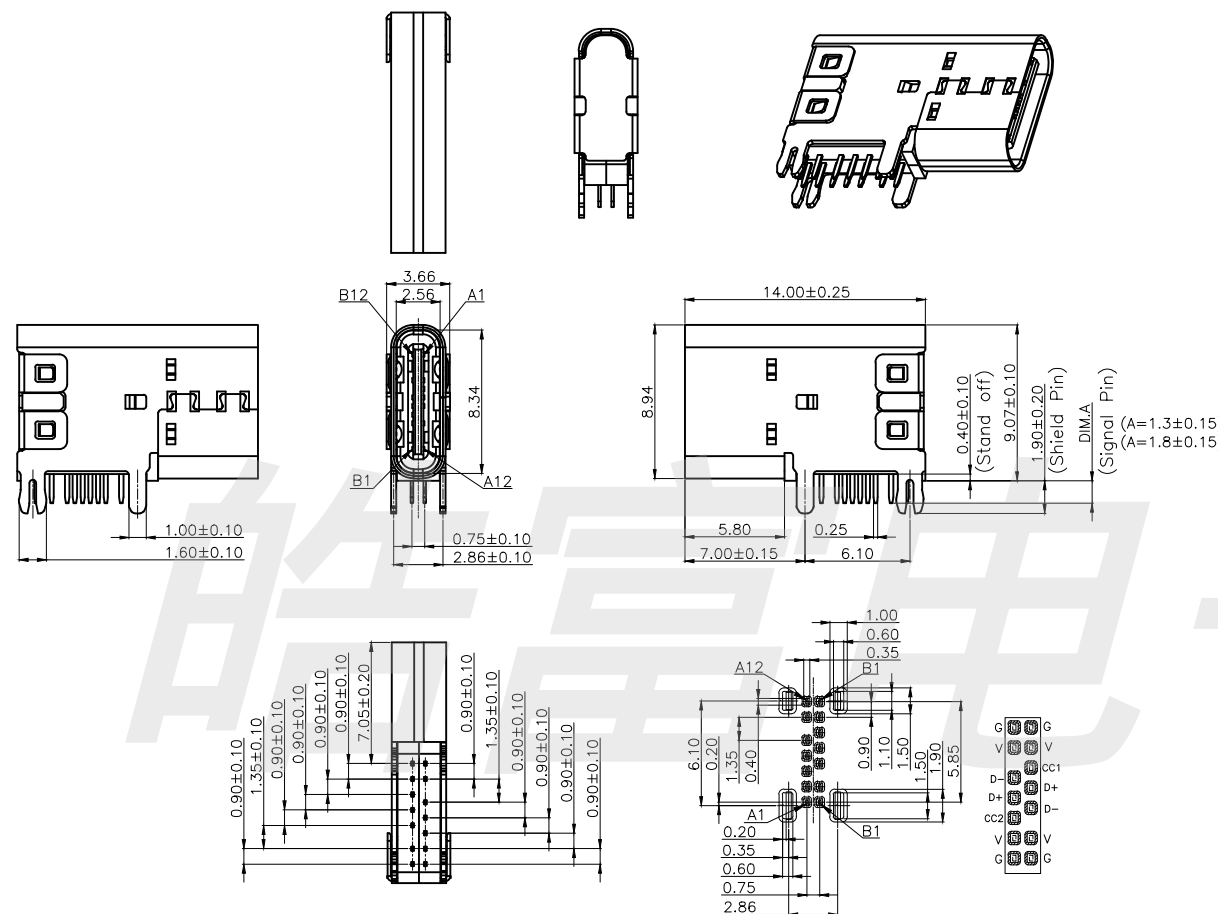

RECOMMENDED P.C.B LAYOUT
TOLERANCE UNSPECIFIED ±0.05mm
Recommended PCB Thickness:1.0mm~1.2mm

HAOFU ELECTRONCS TECHNOLOGY CO.,LTD

COPYRIGHT RESERVED,PLEASE DO NOT COPY.

PART NAME		CONNECTOR		DRAWING	Y,C,ZHANG	DWG.No.	SBICL
PART NO.		TYPE-C 14pin侧插母座后鱼叉脚		CHECK	G.C.Chen	REV.	A1
UNIT : mm	TOLERANCE	UP TO 5	±0.2	APPROVAL	SCALE	DATE	PAGE
	OTHERWISE	ABOVE 5~30	±0.3				
		ABOVE 30	±0.5		2:1		1 OF 1
		ANGLE	±3°				