

Specification:

1. Rating : DC 30V 1.0A.
2. Contact resistance: $\leq 30m\Omega$.
After life test: $\leq 50m\Omega$.
3. Insulation resistance: $\geq 100M\Omega$ (500VDC).
After life test: $\geq 50M\Omega$.
4. Withstand voltage: 500VAC.
5. Insertion and extraction force: 3N~30N.
6. life test: 5000cycles min.
7. Operation temperature range: $-20^{\circ}C \sim 70^{\circ}C$.
8. Preservative temperature range: $-40^{\circ}C \sim 85^{\circ}C$.

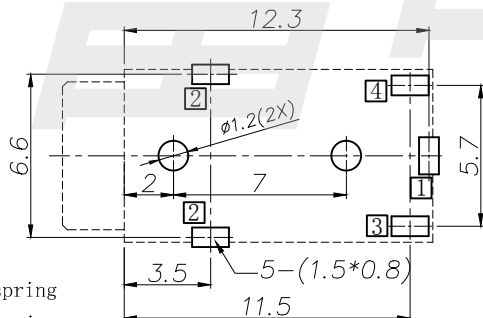

RECOMMENDED P. C. B. LAYOUT
UNSPECIFIED TOLERANCE: ± 0.05
(TOP VIEW)

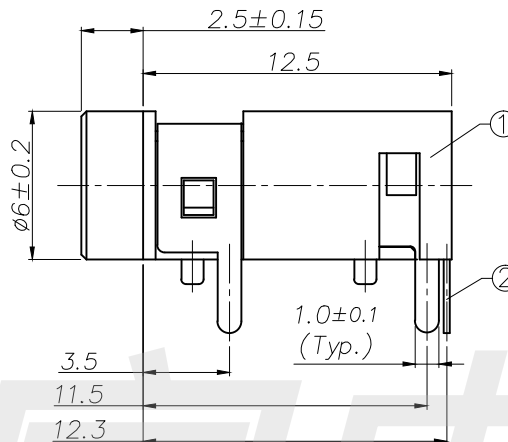
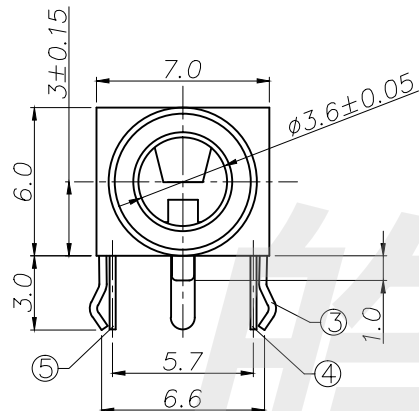
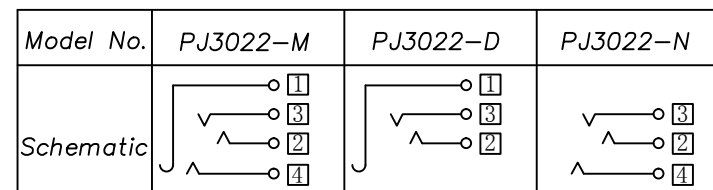
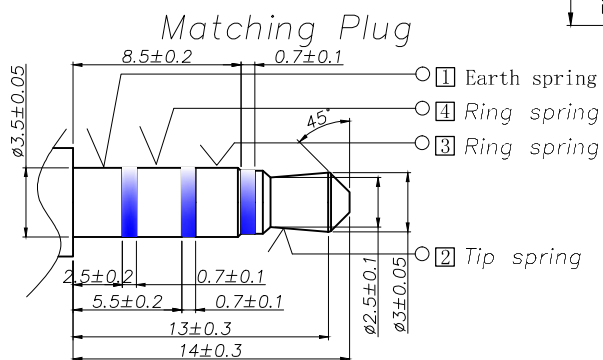
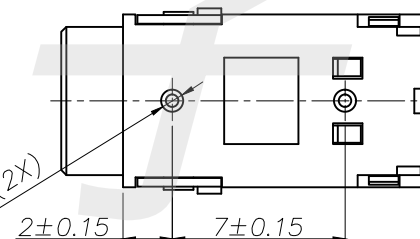

Circuit Diagram: Terminal No.

⑤	Ring spring	④	1	Copper alloy	PJ3522-04(TP-JK0020)	Tin/Ag/Au plating
④	Ring spring	③	1	Copper alloy	PJ3522-03(TP-JK0019)	Tin/Ag/Au plating
③	Tip spring	②	1	Copper alloy	PJ3522-02(JA-JK0039)	Tin/Ag/Au plating
②	Earth spring	①	1	Copper alloy	PJ3522-01(TP-JK0018)	Tin/Ag/Au plating
①	Housing		1	Engineering thermoplastic	PJ3522-S1(ST-JK0022)	UL94V-0
NO.	DESCRIPTION	QTY		MATERIAL	PART NO.	REMARK

HAOFU ELECTRONCS TECHNOLOGY CO.,LTD

PART NAME		PHONE JACK		DRAWING	Y,C,ZHANG	DWG.No.	SBICL
PART NO.		PJ-3022-X		CHECK	G.C.Chen	REV.	A1
UNIT :	TOLERANCE	UP TO 5	±0.2	ANGLE	APPROVAL	DATE	
mm	OTHERWISE	ABOVE 5~30	±0.3	0°±3'	SCALE		
		ABOVE 30	±0.5			PAGE	1 OF 1
		ANGLE	±3'				

COPYRIGHT RESERVED,PLEASE DO NOT COPY.