

FOR REFERENCE ONLY

RoHS Compliant  
Halogen Free

SYMBOL	REV.	REVISION	APPROVAL	DATE

- CONTACT CURRENT RATING: 1A.
- CONTACT RESISTANCE: 100 mΩ MAX.;
- INSULATION RESISTANCE: 1000Ω MIN.;
- DIELECTRIC WITHSTANDING: 500V AC MIN.;
- DURABILITY: 5,000 CYCLES MIN.;
- CONNECTOR MATING FORCES: 30N MAX.;
- CONNECTOR UNMATING FORCES: 3N MIN.;

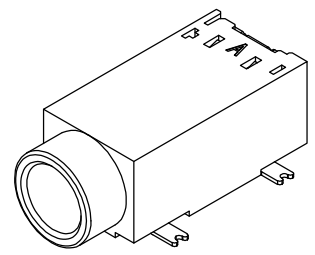
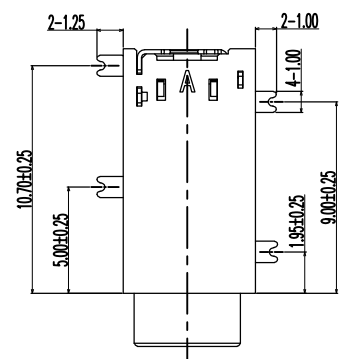

3D VIEW

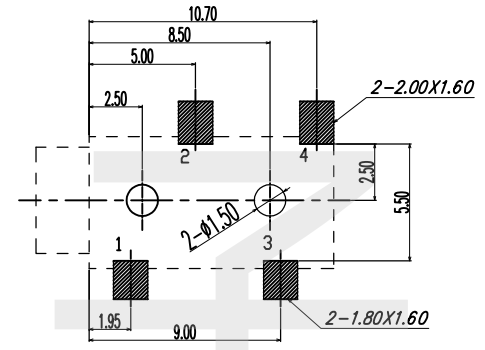
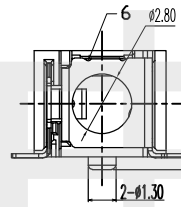
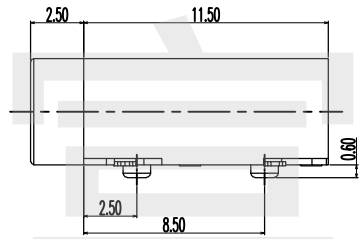
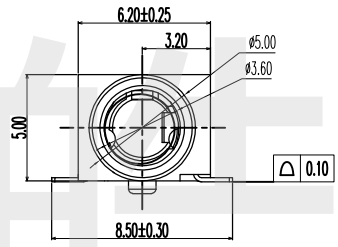

P.C.B LAYOUT  
TOP VIEW

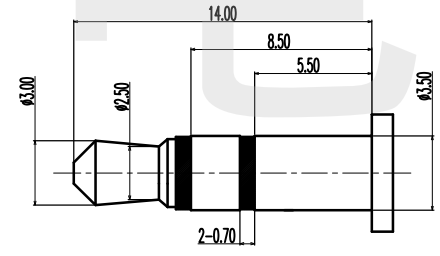
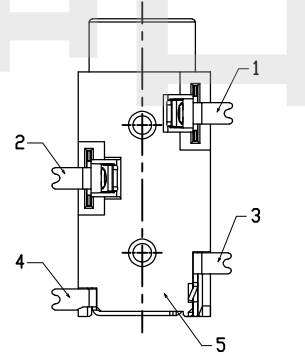

(ø3.50mm 3 POLE PLUG DETAIL DRAWING)

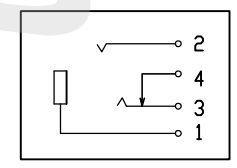

SCHEMATIC

6	FAKE PIN	1	STAINLESS STEEL; CLEANING.	T=0.20mm
5	HOUSING	1	HIGH TEMP PLASTIC,COLOR BLACK.	
4	TERMINAL 4#	1	BRASS; THE BOTTOM OF THE NICKEL;THE WHOLE MATTE TIN PLATING.	T=0.20mm
3	TERMINAL 3#	1	STAINLESS STEEL;THE BOTTOM OF THE NICKEL;THE WHOLE MATTE TIN PLATING.	T=0.20mm
2	TERMINAL 2#	1	PHORPHOS BRONZE; THE BOTTOM OF THE NICKEL;THE WHOLE MATTE TIN PLATING.	T=0.20mm
1	TERMINAL 1#	1		T=0.20mm
ITEM	NAME	Q'TY	DESCRIPTION	NOTE

**CIKI** 东莞市皓富电子科技有限公司  
DONGGUAN CITY HAOFU ELECTRONCS TECHNOLOGY CO.,LTD

COPYRIGHT RESERVED, PLEASE DO NOT COPY.

PART NAME		DC JACK		DRAWING		Z. L. Liang		DWG. No.		ST0015	
PART NO.		PJ-3201B		CHECK		G. C. Chen		REV.		A0	
UNIT :		TOLERANCE UNLESS OTHERWISE SPECIFIED		ANGLE		APPROVAL		DATE		2020-Oct-11	
mm		X. X ± 0.3 X. XX ± 0.2 X. XXX ± 0.1		±2°		SCALE		1:1		PAGE	
								1 OF 1			