

PCB.layout

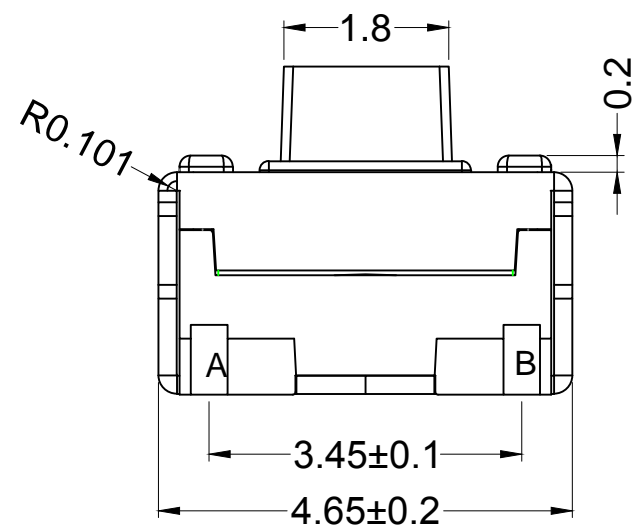

Circuit Diagram

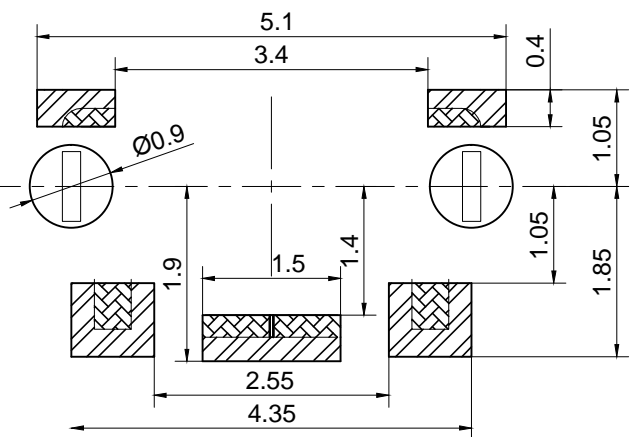
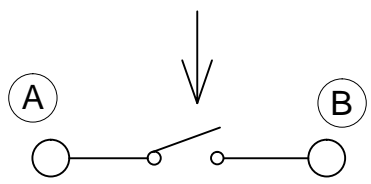

主要技术规格:

1. 额定值: 0.5A DC12V
2. 接触电阻: 50mΩ
3. 操作力: 160±50gf
4. 绝缘电阻: 100MΩ
5. 抗电强度: 250V AC 50HZ 1Min.
6. 寿命: 100000 Cycles
7. 行程: 0.2±0.05mm
8. 使用温度: -30℃~+70℃

材料:

- 1盖 板: 黄铜(镀银)
- 2按钮: PA6T(本色)
- 3弹片: 不锈钢(覆银)
- 4底座: PAKX-208(黑色)
- 5引脚: 黄铜(镀银)
- 6黄膜: 铁氟龙(黄色)
- 7塑胶上盖: PA6T(本色)

东莞市皓富电子科技有限公司

COPYRIGHT RESERVED,PLEASE DO NOT COPY.

PART NAME		TACT SWITCH		DRAWING		Y,C,ZHANG		DWG.No.		SBICL	
PART NO.		TD-1806AN		CHECK		G.C.Chen		REV.		A1	
UNIT :	mm	TOLERANCE OTHERWISE	UP TO 5	±0.2	ANGLE	APPROVAL	SCALE	DATE	PAGE	1 OF 1	
			ABOVE 5~30	±0.3							
			ABOVE 30	±0.5			2:1				
			ANGLE	±3'							