

FOR REFERENCE ONLY

RoHS Compliant
Halogen Free

SYMBOL	REV.	REVISION	APPROVAL	DATE

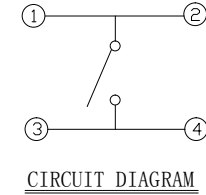
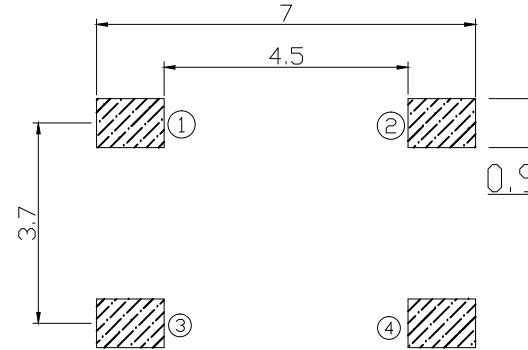
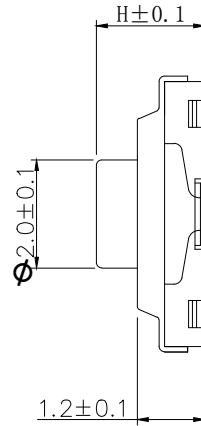
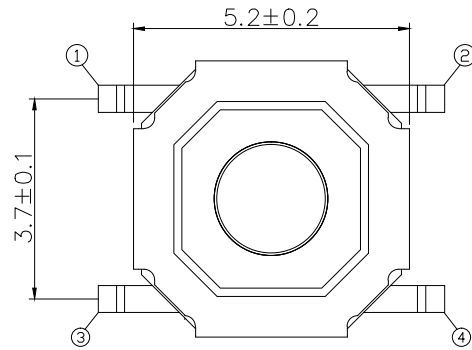

P.C.B LAYOUT

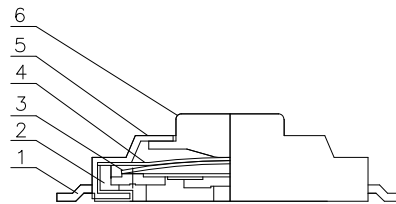
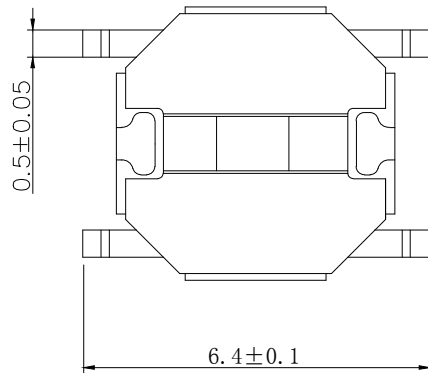

- 主要技术规格:
1. 额定值: 50mA DC12V
 2. 接触电阻: 100mΩ
 3. 操作力: 100/160/260gf±50gf
 4. 行程: 0.15±0.05mm
 5. 绝缘电阻: 100MΩ
 6. 抗电强度: 250V 50HZ 1Min.
 7. 寿命: 10万Cycles

- 材料:
- 1卡 件: 黄铜C5191 (镀银)
 - 2底 座: 塑胶LCP (灰色)
 - 3簧 片: 不锈钢SUS301 (镀银)
 - 4内薄膜: 聚酰亚胺PI (黄色)
 - 5盖 板: 不锈钢SUS304 (清洗)
 - 6按 钮: 黄铜C2680/塑胶PPA (黄色/白色)

H		
1.5	2.5	5.0
1.6	3.0	5.5
1.7	3.5	6.0
1.8	4.0	7.0
2.0	4.3	
2.3	4.5	

CIKI 东莞市皓富电子科技有限公司
DONGGUAN CITY HAOFU ELECTRONICS TECHNOLOGY CO., LTD

COPYRIGHT RESERVED, PLEASE DO NOT COPY.

PART NAME	SWITCH		DRAWING	Z. L. Liang	DWG. No.	ST0015
PART NO.	TD-13XA-H		CHECK	G. C. Chen	REV.	A0
UNIT : mm	TOLERANCE UNLESS OTHERWISE SPECIFIED	X. X ± 0.3 X. XX ± 0.2 X. XXX ± 0.1	ANGLE	G. C. Chen	DATE	
			±2°	SCALE	1:1	PAGE