

PCB 线路板安装图

规格型号		
Model NO.	X=	L=
TC-0302	3.15	4.3
TC-0303	3.85	5.0
TC-0304	4.85	6.0
TC-0305	5.85	7.0
TC-0306	6.85	8.0
TC-0307	7.85	9.0
TC-0308	8.35	9.5
TC-0309	8.85	10.0
TC-0343	9.35	10.5
TC-0344	11.85	13.0

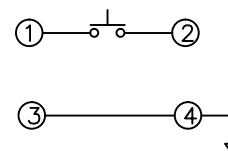
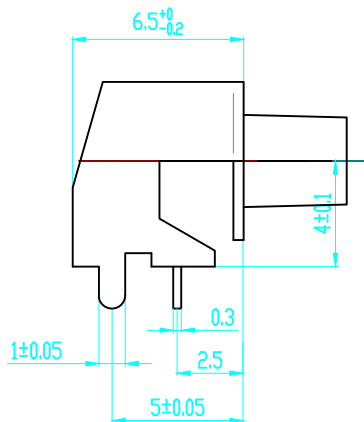
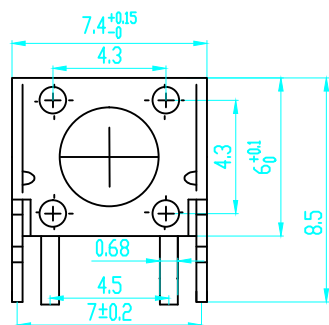

电路图

主要技术规格:

1. 额定值: 50mA DC12V
2. 接触电阻: 100mΩ MAX
3. 操作力: 100gf±15gf
4. 行程: 0.25±0.1mm
5. 绝缘电阻: 100MΩ MIN
6. 抗电强度: 250V 50HZ 1Min.
7. 寿命: 50万Cycles

材料:

- 1 卡件: 磷铜 (镀银)
- 2 簧片: 磷铜 (镀银)
- 3 支架: 铁 (镀锡)
- 4 按钮: PPA (黑色)
- 5 底座: PPA (黑色)

HAOFU ELECTRONCS TECHNOLOGY CO., LTD

COPYRIGHT RESERVED, PLEASE DO NOT COPY.

PART NAME		TACT SWITCH		DRAWING		Y,C,ZHANG		DWG.No.		SBICL	
PART NO.		TC-0303		CHECK		G.C.Chen		REV.		A1	
UNIT :	TOLERANCE OTHERWISE	UP TO 5	±0.2	ANGLE	APPROVAL	DATE		07-06-2014			
		ABOVE 5~30	±0.3			SCALE		2:1		PAGE	
mm		ABOVE 30	±0.5	0°±3'							