

电路图

PCB Layout

主要技术规格:

1. 额定值: 50mA DC12V
2. 接触电阻: 50mΩ
3. 操作力: 160/260gf ± 50gf
4. 行程: 1.30 ± 0.2mm
5. 绝缘电阻: 100MΩ
6. 抗电强度: 250V 50HZ 1Min.
7. 寿命: 10万Cycles

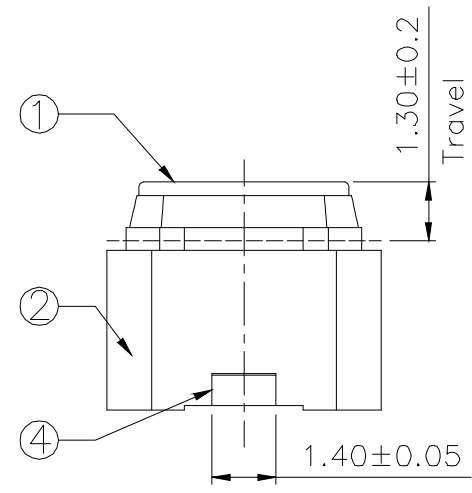
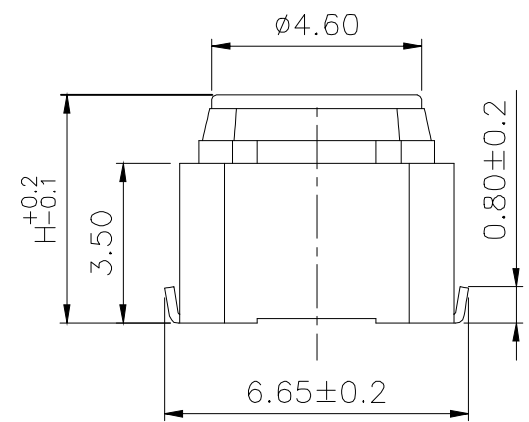

H=4.3/5.0mm

材料:

- ①按钮: LCP (黑色)
- ②底座: LCP (黑色)
- ③簧片: 不锈钢 (镀银)
- ④端子: 磷铜 (镀银)
- ⑤防水膜: 进口聚酰亚胺

HAOFU ELECTRONCS TECHNOLOGY CO.,LTD

COPYRIGHT RESERVED,PLEASE DO NOT COPY.

PART NAME		SWITCH		DRAWING	Y,C,ZHANG	DWG.No.	SBICL
PART NO.		TD-31XB-H		CHECK	G.C.Chen	REV.	A1
UNIT :	TOLERANCE OTHERWISE	UP TO 5	±0.2	ANGLE	APPROVAL	DATE	14-03-2013
		ABOVE 5~30	±0.3			SCALE	PAGE
mm		ABOVE 30	±0.5	0°±3'	2:1		
		ANGLE	±3'				