

RoHS Compliant
Halogen Free

SYMBOL	REV.	REVISION	APPROVAL	DATE

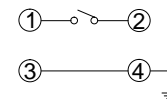
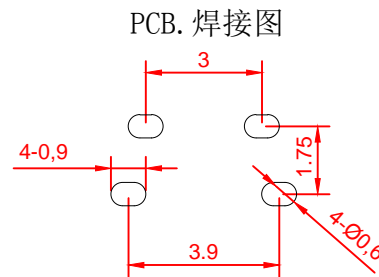
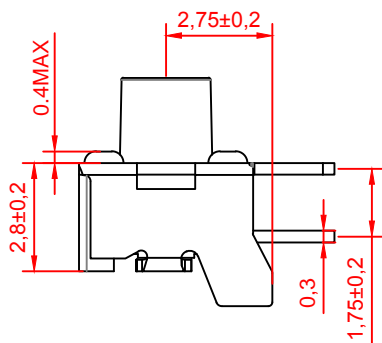
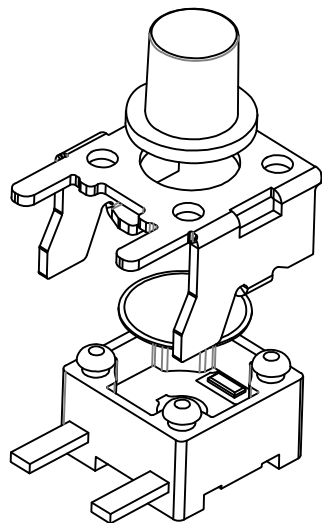

电路图

H	
3.5	3.8
4.3	4.5
5.0	5.5
6.0	6.5
.....
10.0	10.5

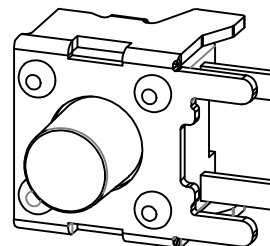
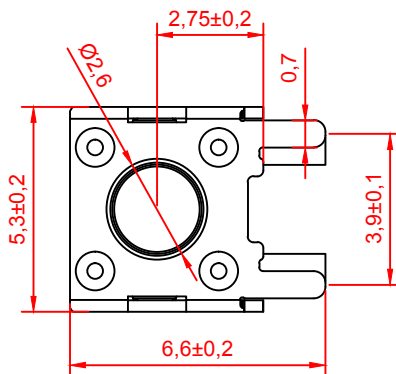
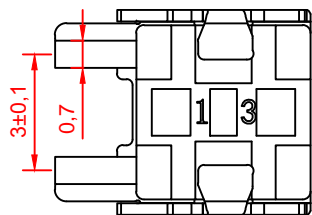

主要技术规格:

1. 额定值: 50mA DC12V
2. 接触电阻: ≤50mΩ
3. 操作力: 160±40gf
4. 行程: 0.2±0.1mm
5. 绝缘电阻: ≥100MΩ
6. 抗电强度: 250V 50HZ 1min.
7. 寿命: 10万Cycles

材料:

- ①按钮: PPA (黑色)
- ②支架: 冷轧钢 (镀锡)
- ③弹片: 不锈钢 (复银)
- ④本体: PPA (黑色)
- ⑤端子: 黄铜 (镀银)

CIKI 东莞市皓富电子科技有限公司
DONGGUAN CITY HAOFU ELECTRONCS TECHNOLOGY CO., LTD

COPYRIGHT RESERVED, PLEASE DO NOT COPY.

PART NAME		TACT SWITCH		DRAWING		Z. L. Liang		DWG. No.		
PART NO.		TC-1109AQ-H		CHECK		G. C. Chen		REV.		A0
UNIT :	mm	TOLERANCE UNLESS	X. X ± 0.3	ANGLE	APPROVAL	G. C. Chen	DATE	PAGE	1 OF 1	
		OTHERWISE SPECIFIED	X. XX ± 0.2							±2°