

CAD FILE:

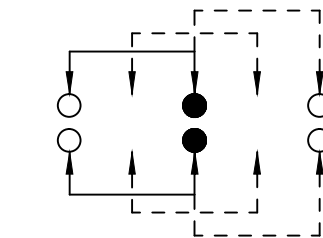

SCHEMATIC (NON-SHORTING)

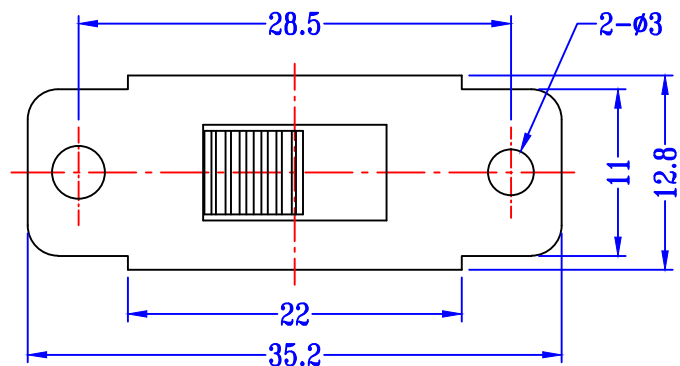
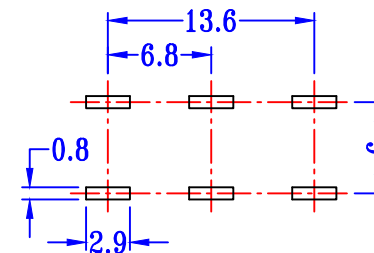
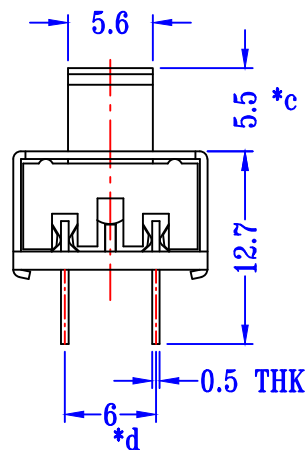
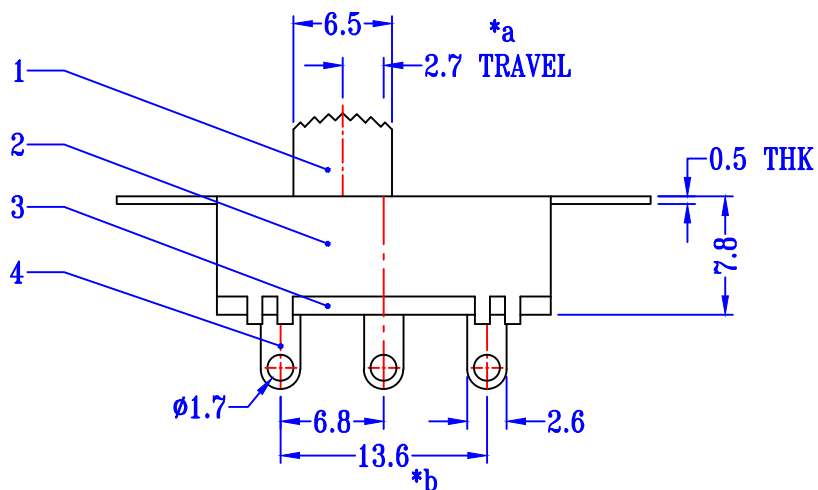

P.C.B LAYOUT
BOTTOM VIEW

注：“*”表示关键尺寸（4个）。

8	CONTACT CLIP	PBS STRIP	2	Ag PLATED	TOLERANCE UNLESS SPECIFIED					
7	POSITION PLATE	STEEL STRIP	1	Ni PLATED						
6	STEEL BALL	STEEL	1	NATURAL	WITHIN 1.5mm : ±0.1mm	A	2012-8-4	初版		
5	SPRING	STEEL WIRE	1	NATURAL	OVER 1.5mm : ±0.2mm	ISSUE	DATE	DESCRIPTIONS OF REVISION	APPD.	
4	TERMINAL	BRASS STRIP	6	Ag PLATED	TITLE : VERTICAL SLIDE SWITCH		UNIT : mm	DRWG NO.: HF-DR-SS23E285.5-00		
3	BASE	PHENOLIC RESIN	1	NATURAL	MODEL: SS-23E28G5.5		SCALE: 2 : 1	DWN.	余丽珍	2012-8-4
2	FRAME	STEEL STRIP	1	Ni PLATED	东莞市皓富电子科技有限公司 DONGGUAN HAOFU ELECTRONIC TECHNOLOGY CO.,LTD.			CHK'D	卢业创	2012-8-4
1	KNOB	POM	1	BLACK				APPD.		
NO.	PARTS	MATERIALS	Q'TY	FINISH						