

CAD FILE:

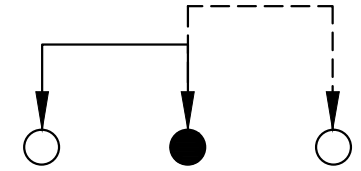

SCHEMATIC (NON-SHORTING)

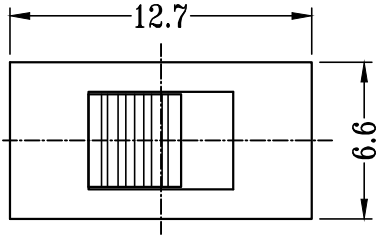
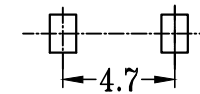
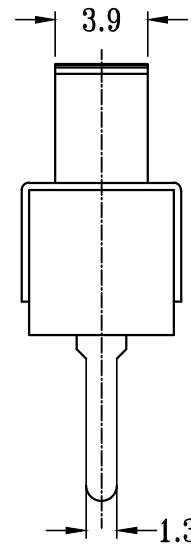
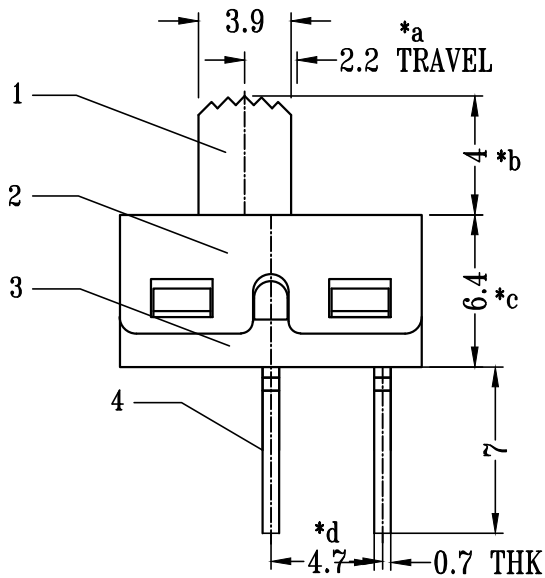

P.C.B LAYOUT
BOTTOM VIEW

注：“*”表示关键尺寸(4个)

NO.	PARTS	MATERIALS	Q'TY	FINISH	TOLERANCE UNLESS SPECIFIED					
8										
7	STEEL BALL	STEEL	1	NATURAL						
6	SPRING	STEEL WIRE	1	NATURAL	WITHIN 1.5mm : ±0.1mm	A	2012-8-7	初板		
5	CONTACT	BRASS STRIP	1	Ag PLATED	OVER 1.5mm : ±0.2mm	ISSUE	DATE	DESCRIPTIONS OF REVISION		APPD.
4	TERMINAL	BRASS STRIP	3	Ag PLATED	TITLE : VERTICAL SLIDE SWITCH		UNIT : mm	DRWG NO.: HF-DR-SS12D10G5-00		
3	CASE	PA66	1	BLACK	MODEL: SS-12D104G5		SCALE: 3:1	DWN.	余丽珍	2012-8-7
2	COVER	SUS	1	NATURAL	东莞市皓富电子科技有限公司 DONGGUAN CITY HAOFU ELECTRONCS TECHNOLOGU CO.,LTD		CHK'D			
1	KNOB	PA66	1	BLACK			APPD.			